

NCGD-46-S COUNTERTOP GELATO DISPLAY

Ideal for ice cream shops, restaurants and cafés



FEATURES

6 x 1/3 gastronorm pans included

Double-tempered glass with heater to prevent fogging

Ventilated cooling system & automatic defrost

Sliding doors at the back

Digital temperature controller with LED display

Brilliant cool-toned LED at top of unit

4 adjustable feet

High-performance condenser with automatic water evaporation



SPECIFICATIONS



Capacity (Cu. ft)	3.17
Capacity (Liters)	15 L (6 x 1/3 gastronorm pans)
Exterior Dimensions (in)	46" x 33" x 24.5"
Package Dimensions (in)	49" x 36" x 31"
Shelf	6 pans
Door(s)	Sliding at the back
Temperature Range (°C)	-22°C TO -12°C
Ambient Temperature	≤ 30°C
Ambient Humidity	≤ 55%
Refrigerant (CFC-Free)	R290
Voltage (V)	110 - 120 V / 60Hz
Plug Type	NEMA 5-20P
Amperage	9A
Net Weight (kg/lb)	93kg / 205lb

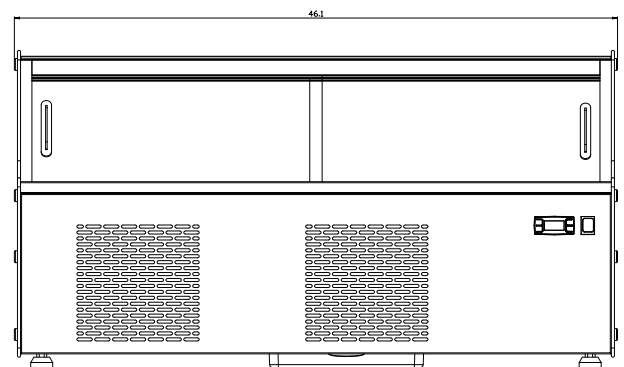
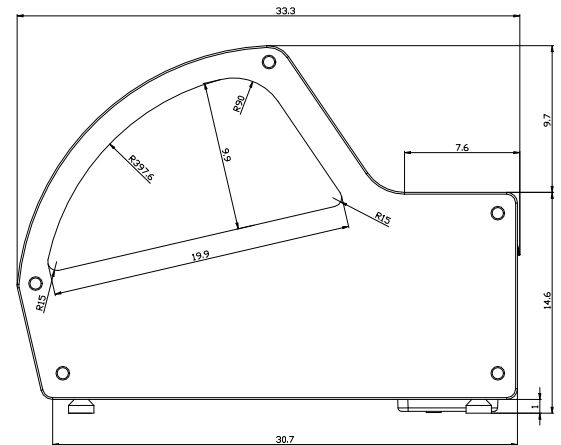

*Design and specifications may change without prior notice for product improvement

CUSTOMER SUPPORT



1-800-567-3620

NEWAIRREFRIGERATION.CA



NCGD-46-S-V1.0-202605